

JED MICROPROCESSORS PTY LTD
 BORONIA VICTORIA 3155
 Board title 213v0.PCB

Date
 Scale
 Time

27-Jul-2004
 SCALE: 2.04
 11:39:39

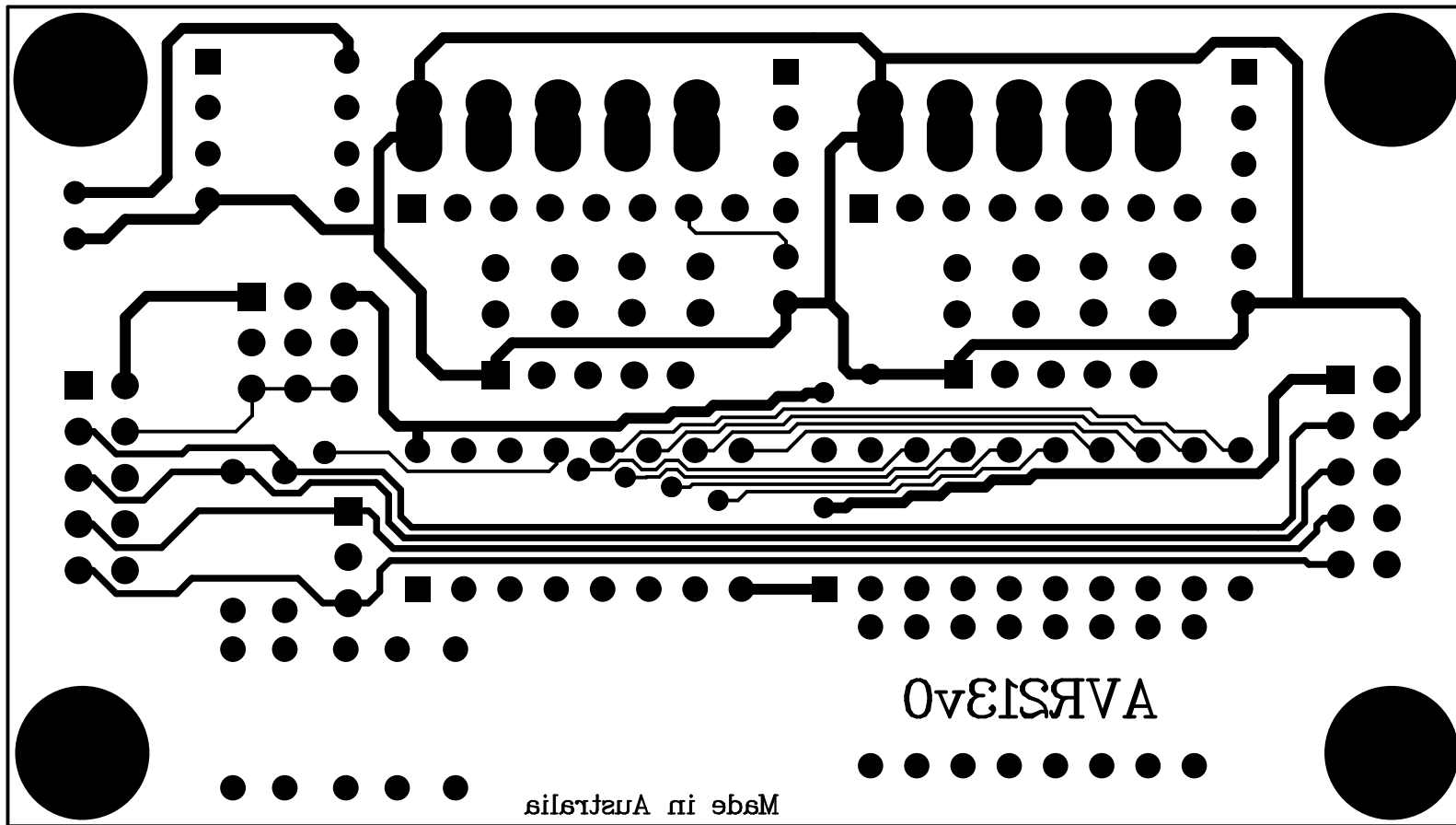

JED MICROPROCESSORS PTY LTD
BORONIA VICTORIA 3155
Board title 213v0.PCB

Date
Scale
Time

27-Jul-2004
SCALE: 2.04
11:39:40

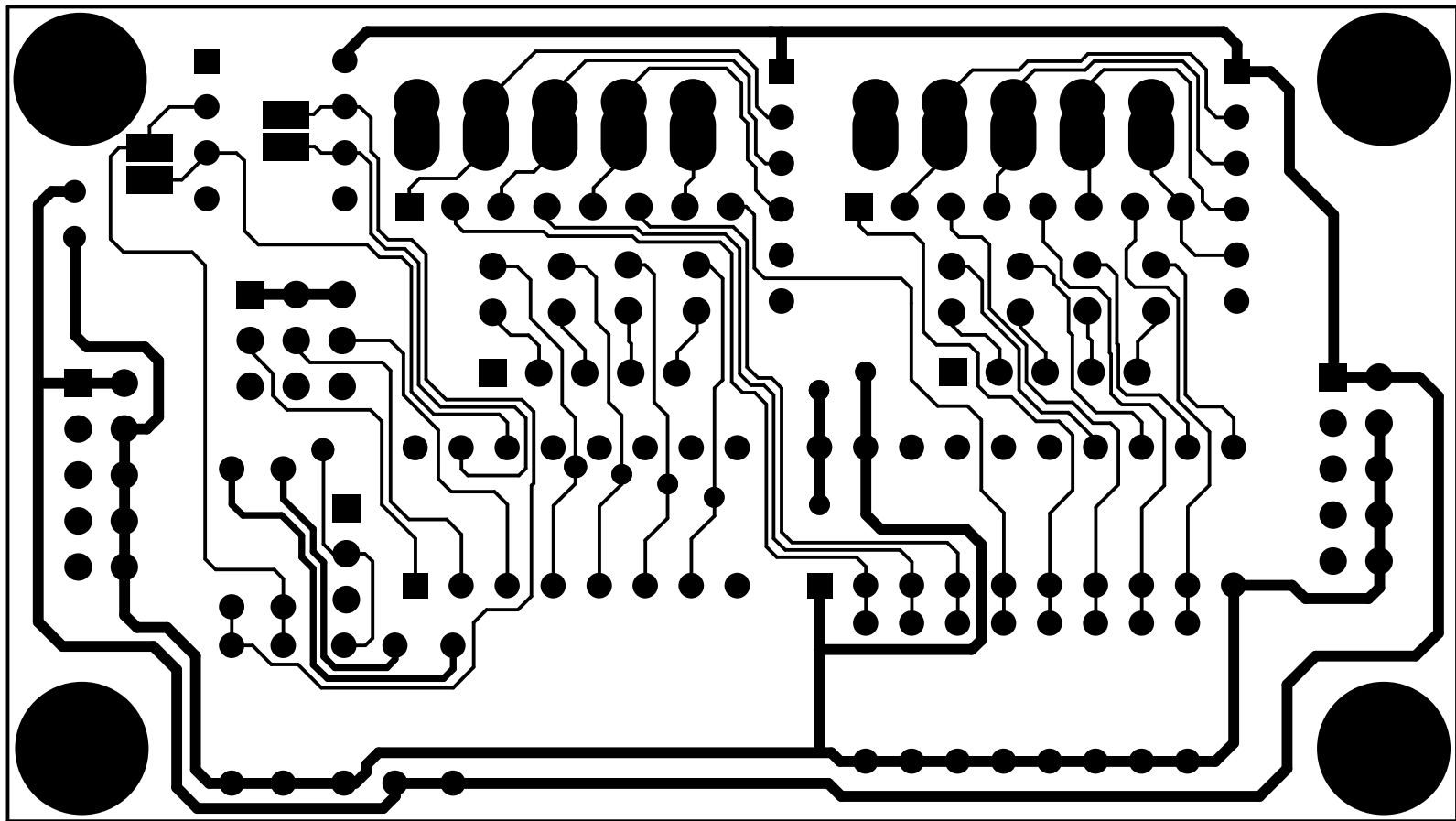

JED MICROPROCESSORS PTY LTD
BORONIA VICTORIA 3155
Board title 213v0.PCB

Date
Scale
Time

27-Jul-2004
SCALE: 2.04
11:39:40

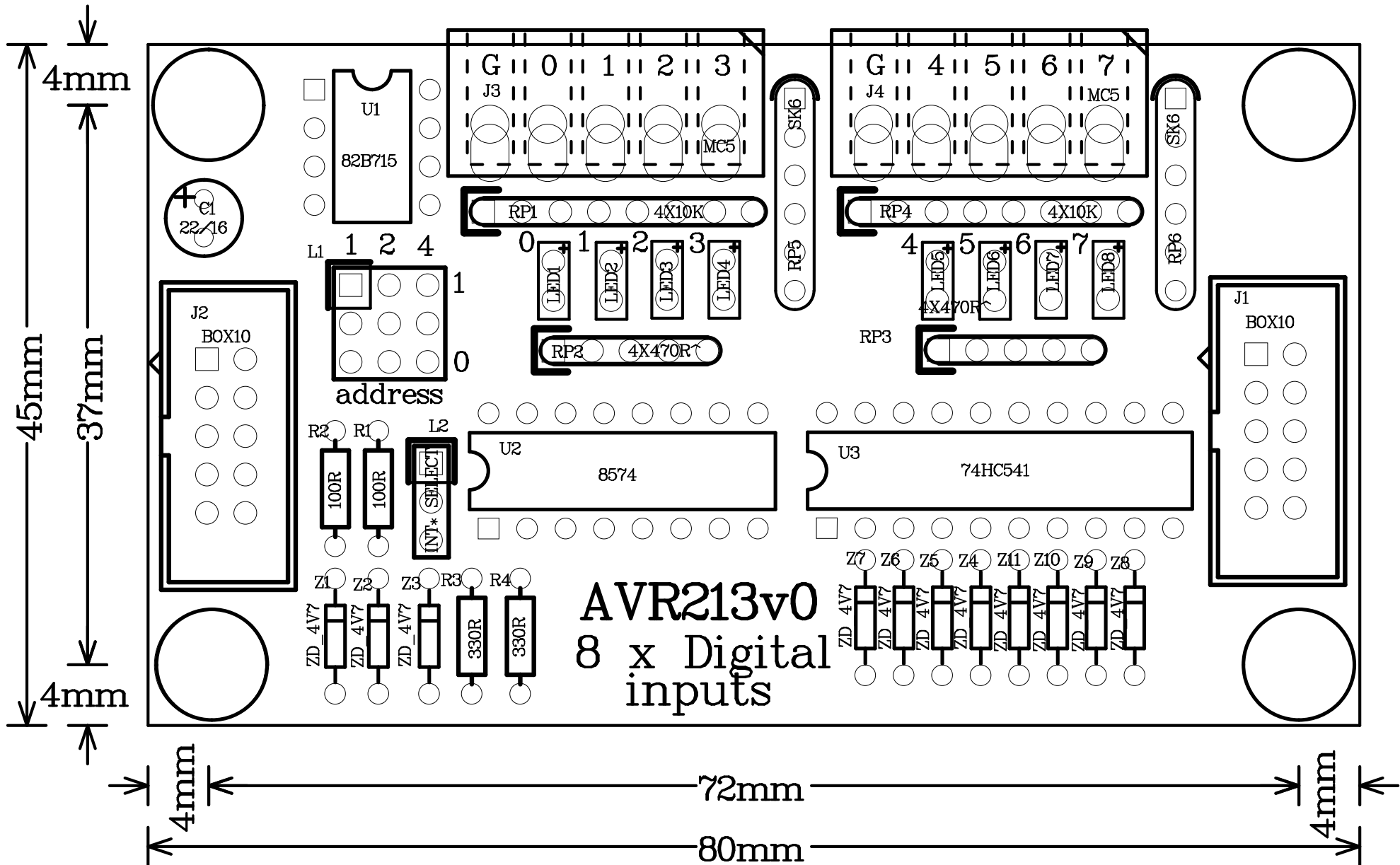

JED MICROPROCESSORS PTY LTD
 BORONIA VICTORIA 3155
 Board title Bits of 213v0.PCB

Date
 Scale
 Time

27-Jul-2004
 SCALE: 2.84
 11:39:23

I2C interface
213v0.S01

I2C interface

8 x DIGITAL INPUTS
213v0.S02

DIGITAL INPUTS

JED MICROPROCESSORS PTY LTD 173 BORONIA ROAD, BORONIA, VIC, 3155 Ph (03) 9762 3588 Fax (03) 9762 5499 Email: jed@jedmicro.com.au		
TITLE 8 x FET DRIVERS		
PROJECT NUMBER 213v0.Sch		
VERSION 0	DATE 27-Jul-2004	SHEET 1 OF 3

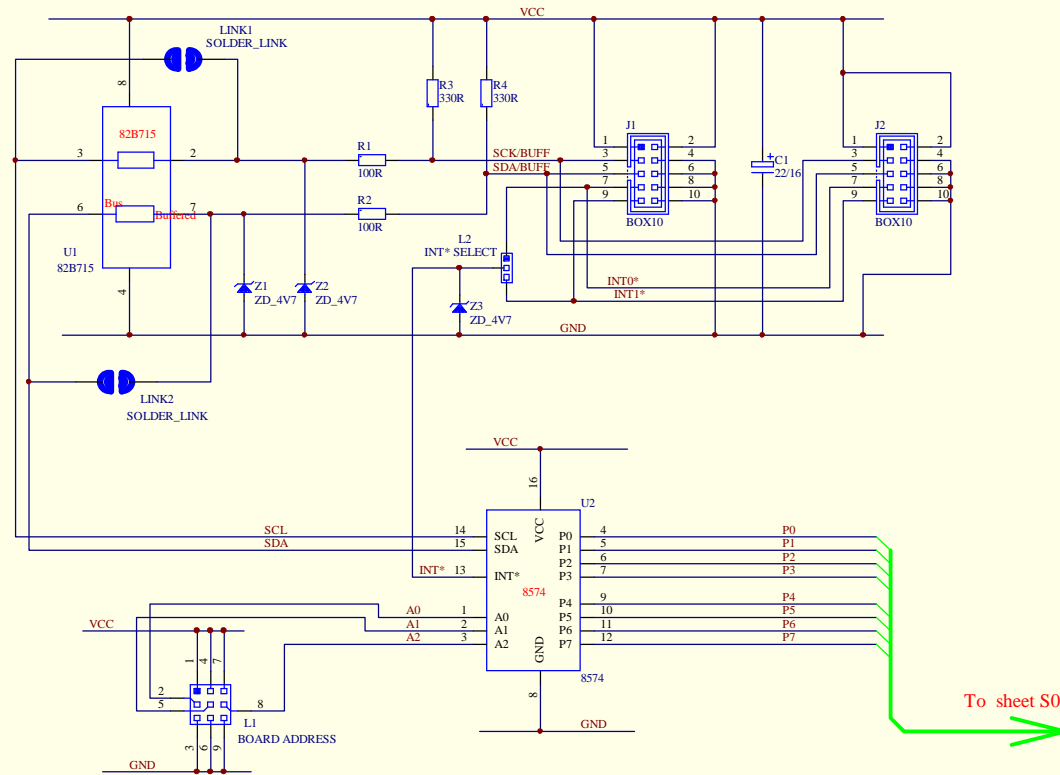

To sheet S02

JED MICROPROCESSORS PTY LTD 173 BORONIA ROAD, BORONIA, VIC, 3155 Ph (03) 9762 3588 Fax (03) 9762 5499 Email: jed@jedmicro.com.au		
TITLE I2C interface		
PROJECT NUMBER 213v0.S01		
VERSION 0	DATE 27-Jul-2004	SHEET 2 OF 3

U3 is a buffer mounted in a socket.
 If it is a 74HC540 it is an inverting buffer.
 If it is a 74HC541 it is a non inverting buffer.

Note that RP5 & RP6 are mounted in sockets with an extra position so that they can be inserted either way around.
 If they have the common lead connected to GND then they act as pull down resistors.
 If they have the common lead connected to VCC then they act as pull up resistors.

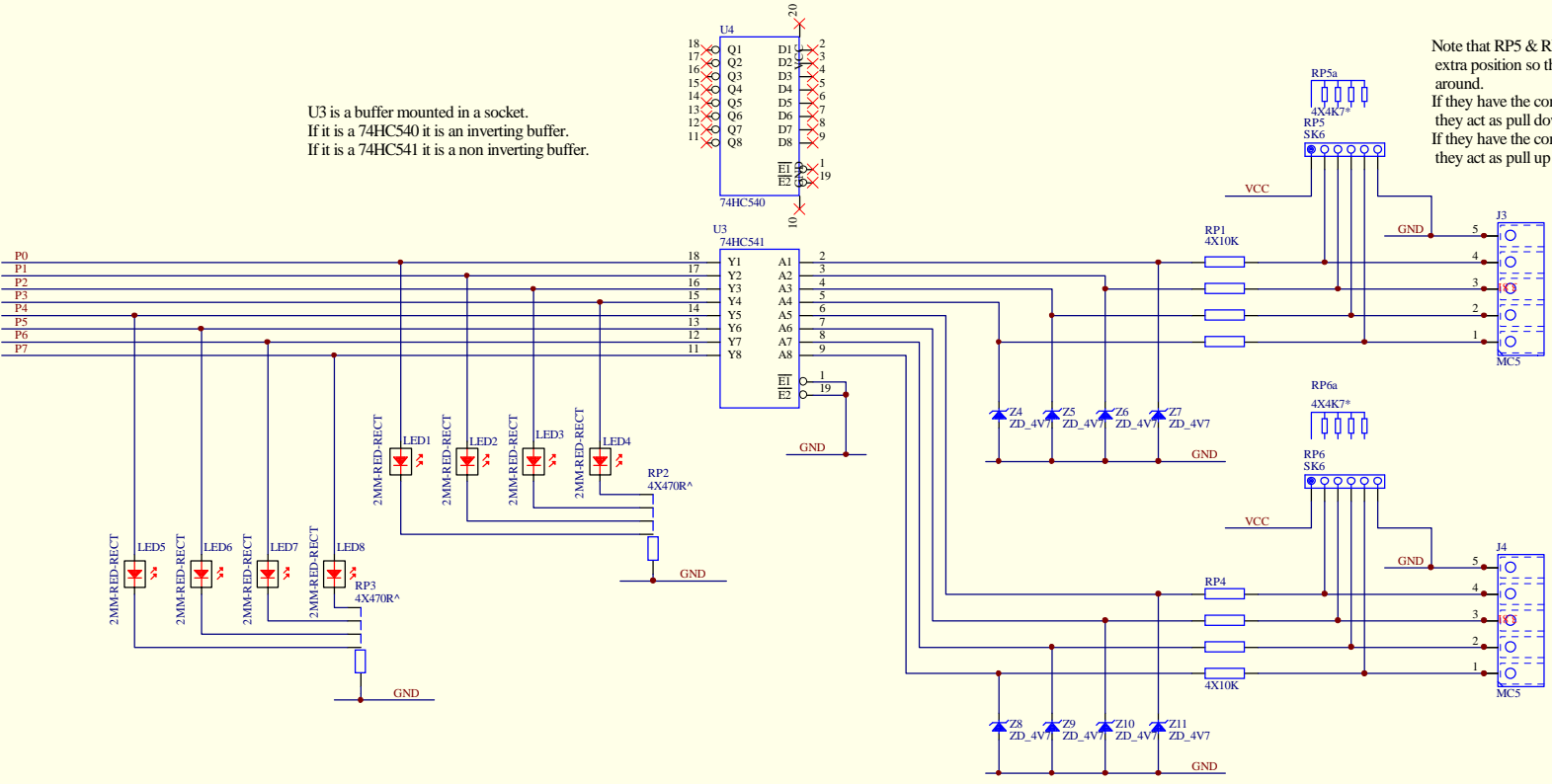

JED MICROPROCESSORS PTY LTD 173 BORONIA ROAD, BORONIA, VIC, 3155 Ph (03) 9762 3588 Fax (03) 9762 5499 Email: jed@jedmicro.com.au		
TITLE Interface		
PROJECT NUMBER 213v0.S02		
VERSION 0	DATE 27-Jul-2004	SHEET 3 OF 3